

THIS DRAWING IS SUPPLIED FOR INFORMATION ONLY. DESIGN FEATURES, SPECIFICATIONS AND PERFORMANCE DATA SHOWN HEREON ARE THE PROPERTY OF THE AMPHENOL CORPORATION. NO RIGHTS OF REPRODUCTION ARE IMPLIED. ALL DIMENSIONS ARE SUBJECT TO NORMAL MANUFACTURING VARIATIONS.

**Customer Drawing**

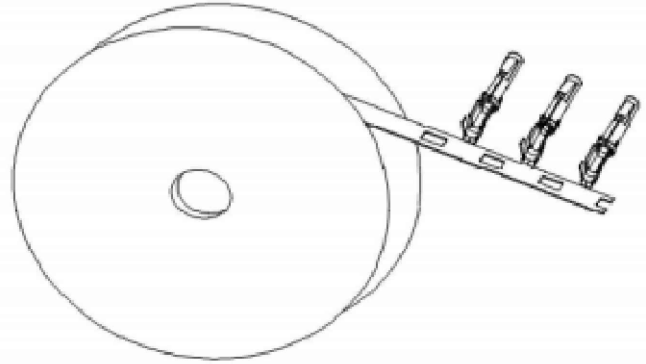

Contact Orientation On Reel  
For Auto Crimp Machine

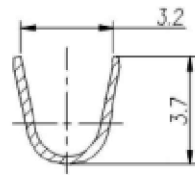
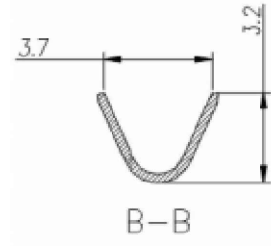

6		7			8	
REVISIONS						
REV	ZONE	ECO	DESCRIPTION	DATE	BY	APPR
A	--	--	INITIAL RELEASE	01/30/15	RW	EC
B	--	--	Remove the tin-plated terminal	05/12/20	JS	JL

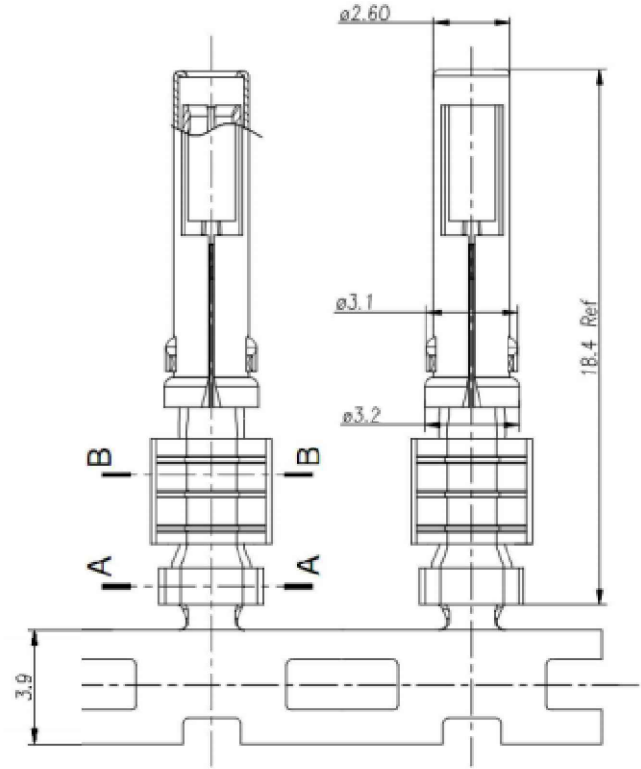

注(NOTES):

1. 对配公端直径 Mating contact diameter:1.6mm
2. 额定电流 Current rating: 13A
3. 端子类型 Terminatin type: Crimp
4. 压线规格 Wire size: AWG14
- △ 5. 电镀信息 Plating specification:  
镍底, 整个端子镀金.  
Gold flash plate overall.
6. 材料规格 Material specification:
  - 6.1. 端子: 铜合金  
Contact body: Copper alloy
  - 6.2. 外套: 不锈钢  
Outer spring: Stainless steel
7. 符合ROHS  
ROHS compliant

		Amphenol Technical Products International GZ				
		第三角投影 THIRD ANGLE PROJECTION	页面 SHEET	幅面 SIZE	版次 REV.	比例 SCALE
签名 SIGNATURE		日期 DATE		UNLESS OTHERWISE SPECIFIED 1) All dimensions are in metric(mm). 2) Tolerances are as follows: 1 PL DEC ±1.00 2 PL DEC ±0.50 3 PL DEC ±0.20		DWG NO: HCTF21401
制图 DRAWN	JS	05/12/20	1 OF 1		A3	B
审核 CHECKED	YM	05/12/20	批准 APPROVAL		JL	05/12/20
					Angles ±1°	CUST PART #: N/A
						CUST REV. -