

THIS DRAWING IS SUPPLIED FOR INFORMATION ONLY. DESIGN FEATURES, SPECIFICATIONS AND PERFORMANCE DATA SHOWN HEREON ARE THE PROPERTY OF THE AMPHENOL CORPORATION. NO RIGHTS OF REPRODUCTION ARE IMPLIED. ALL DIMENSIONS ARE SUBJECT TO NORMAL MANUFACTURING VARIATIONS.

Customer Drawing

Amphenol TPI
2022 -03- 17
REGISTERED COPY

REVISIONS						
REV	ZONE	ECO	DESCRIPTION	DATE	BY	APPR
A	---	---	INITIAL RELEASE	12/01/14	RW	EC
B	---	---	料号更改从HCTF200X改为HCTF1200X	01/28/15	RW	EC
C	---	---	更改压接区尺寸	02/06/18	YM	JG
D	---	---	Remove the tin-plated terminal	05/12/20	JS	JL
E	---	---	Add tolerance	03/16/22	JS	JL

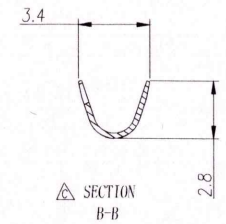
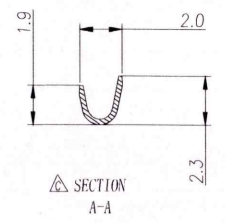
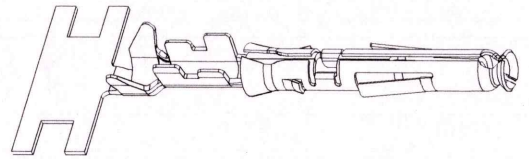
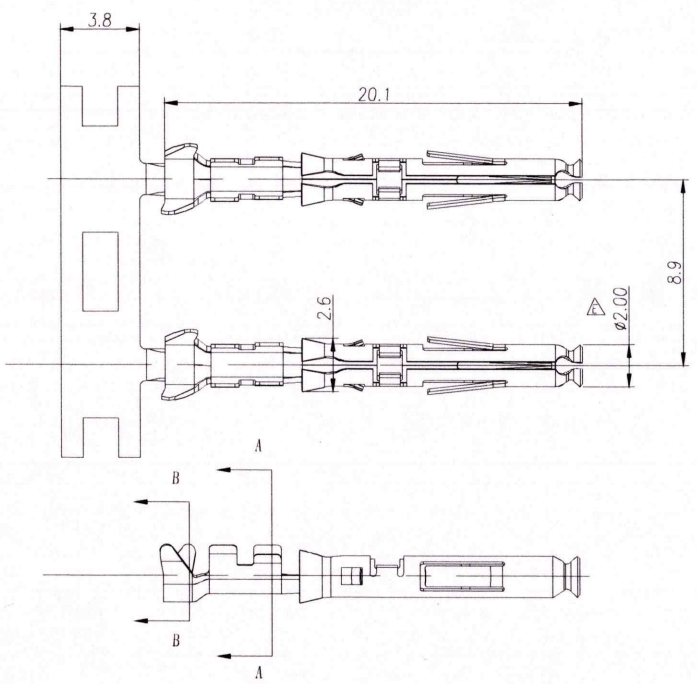

- 注 (NOTES):
1. 对配公端直径 Mating contact diameter: 1.0mm
 2. 额定电流 Current rating: 5A
 3. 端子类型 Terminatin type: Crimp
 4. 压线规格 Wire size :AWG20~22
 5. 电镀信息 Plating specification:
镍底, 整个端子镀金.
Gold flash plate overall.
 6. 材料规格 Material specification:
6.1. 端子: 铜合金
Contact body: Copper alloy
6.2. 外套: 不锈钢
Outer spring: Stainless steel
 7. 符合ROHS
ROHS compliant

		Amphenol Technical Products International GZ				
		第三角投影 THIRD ANGLE PROJECTION	页面 SHEET	幅面 SIZE	版次 REV.	比例 SCALE
签名 SIGNATURE		日期 DATE		UNLESS OTHERWISE SPECIFIED 1) All dimensions are in metric(mm). 2) Tolerances are as follows: 1 PL DEC ±1.00 2 PL DEC ±0.50 3 PL DEC ±0.20		DWG NO: HCTF12001
制图 DRAWN	JS	03/16/22	1 OF 1		A3	E
审核 CHECKED	JG	03/16/22	1 PL DEC ±1.00 2 PL DEC ±0.50 3 PL DEC ±0.20		Angles ±1°	CUST PART # N/A
批准 APPROVAL			03/16/22			CUST REV -

THIS DRAWING IS SUPPLIED FOR INFORMATION ONLY. DESIGN FEATURES, SPECIFICATIONS AND PERFORMANCE DATA SHOWN HEREON ARE THE PROPERTY OF THE AMPHENOL CORPORATION. NO RIGHTS OF REPRODUCTION ARE IMPLIED. ALL DIMENSIONS ARE SUBJECT TO NORMAL MANUFACTURING VARIATIONS.

Customer Drawing

REVISIONS						
REV	ZONE	ECO	DESCRIPTION	DATE	BY	APPR
A	---	---	INITIAL RELEASE	12/01/14	RW	EC
B	---	---	料号更改从HCTF20XX改为HCTF120XX	01/28/15	RW	EC
C	---	---	更改压接区尺寸	02/06/18	YM	JG
D	---	---	Remove the tin-plated terminal	05/12/20	JS	JL
E	---	---	Add tolerance	03/16/22	JS	JL

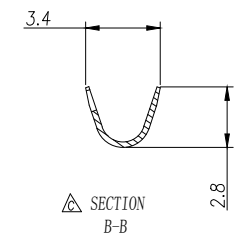
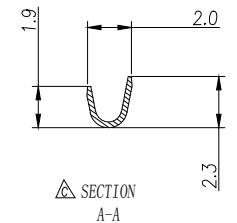
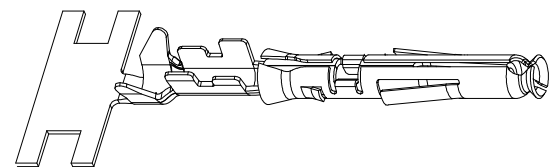
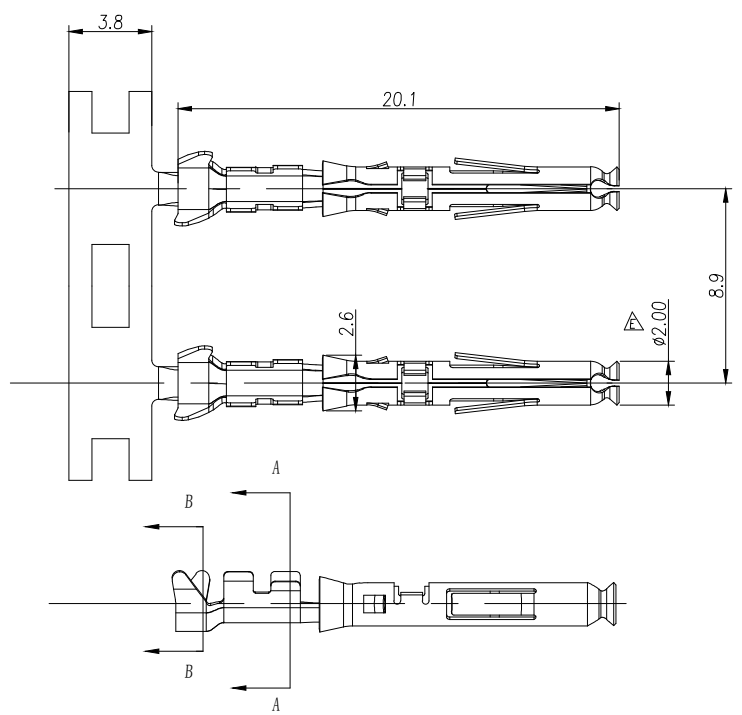

- 注(NOTES):
1. 对配公端直径 Mating contact diameter:1.0mm
 2. 额定电流 Current rating: 5A
 3. 端子类型 Terminatin type: Crimp
 4. 压线规格 Wire size :AWG20~22
 5. 电镀信息 Plating specification:
 镀底, 整个端子飘金.
 Gold flash plate overall.
 6. 材料规格 Material specification:
 6.1. 端子: 铜合金
 Contact body: Copper alloy
 6.2. 外套: 不锈钢
 Outer spring: Stainless steel
 7. 符合ROHS
 ROHS compliant

	Amphenol Technical Products International GZ					PART NAME: HC Contact 20#Socket 20~22AWG	
	第三角投影 THIRD ANGLE PROJECTION	页 面 SHEET	幅 面 SIZE	版 次 REV.	比 例 SCALE	DWG NO: HCTF12001	
签名 SIGNATURE		日期 DATE		UNLESS OTHERWISE SPECIFIED		CUST PART #: N/A	
制 图 DRAWN	JS	03/16/22	1) All dimensions are in metric(mm). 2) Tolerances are as follows:		GUST REV. -		
审 核 CHECKED	JG	03/16/22	1 PL DEC ±1.00 2 PL DEC ±0.50 3 PL DEC ±0.20		Angles ±1°		
批 准 APPROVAL	JL	03/16/22					