

THIS DRAWING IS SUPPLIED FOR INFORMATION ONLY. DESIGN FEATURES, SPECIFICATIONS AND PERFORMANCE DATA SHOWN HEREON ARE THE PROPERTY OF THE AMPHENOL CORPORATION. NO RIGHTS OF REPRODUCTION ARE IMPLIED. ALL DIMENSIONS ARE SUBJECT TO NORMAL MANUFACTURING VARIATIONS.

Customer Drawing

REV		ZONE	ECO	DESCRIPTION	DATE	BY	APPR
				REVISIONS			
A	--	--	--	INITIAL RELEASE	07/14/15	RW	EC
B	--	--	--	Change back shell	11/17/16	SW	TS
C	--	--	--	Add rating current	03/07/19	Steven	JL

订购信息 Ordering Information

PL28 X - 20 1 - 50		
键位及颜色 Key & Color	高压互锁 HVIL	线缆大小 Cable Size
"X", 橙色 Orange	0, 不带互锁 No HVIL	"50"=50mm ²
"Y", 黑色 Black	1, 带互锁 With HVIL	"35"=35mm ²
"U", 黄色 Yellow		"25"=25mm ²
"V", 绿色 Green		
"W", 红色 Red		

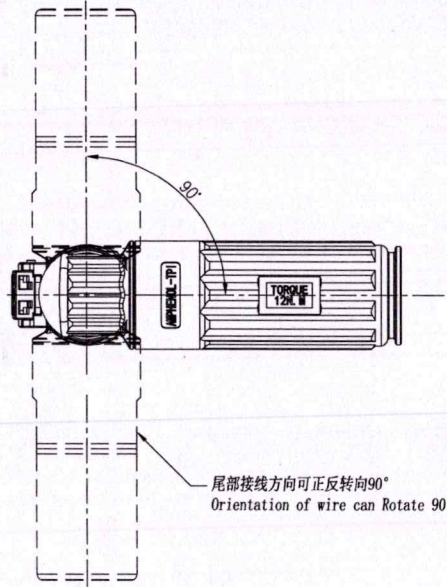

尾部接线方向可正反转向90°
Orientation of wire can Rotate 90 Degrees

Amphenol TPI
2019-12-09
REGISTERED COPY

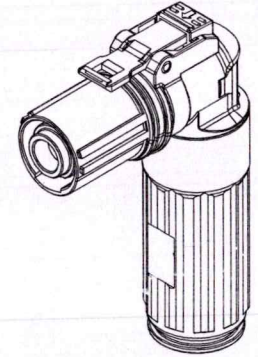

按键颜色见“订购信息”
The color of press key see "Ordering Information"

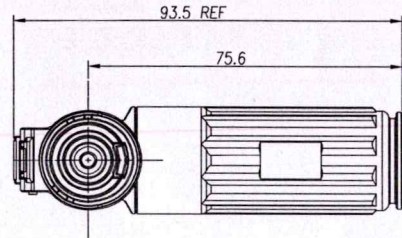
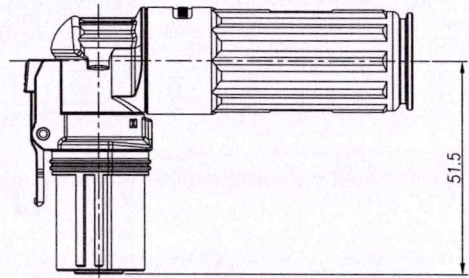
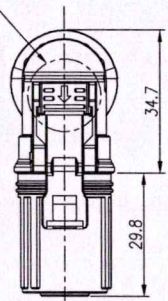

规格参数 (Spec.):

- 工作温度 Operating temperature: -40° C~+125° C.
- 额定电流 Current rating (Connector Only):
50mm²-200 A 35mm²-150A 25mm²-120A.
- 额定电压 Operating voltage: 1000 VDC.
- 耐电压 Dielectric withstanding voltage: 5000 VDC.
- 防护等级 Protection class: IP67 & IP2X.
- 电磁屏蔽 Shielding.
- 机械寿命 Mating cycle: 100 Min.
- 带自动二次锁扣 Automatic secondary lock.
- 尾部接线方向可正反转向90° Rotate function of wire.
- 带高压互锁 Electrical interlock (HVIL).
- 配对插座 Mating receptacle: See drawing "PL00-200"

Standard Part List
(With HVIL)

P/N
PL28X-201-25
PL28Y-201-25
PL28U-201-25
PL28V-201-25
PL28W-201-25
PL28X-201-35
PL28Y-201-35
PL28U-201-35
PL28V-201-35
PL28W-201-35
PL28X-201-50
PL28Y-201-50
PL28U-201-50
PL28V-201-50
PL28W-201-50

Standard Part List
(Without HVIL)

P/N
PL28X-200-25
PL28Y-200-25
PL28U-200-25
PL28V-200-25
PL28W-200-25
PL28X-200-35
PL28Y-200-35
PL28U-200-35
PL28V-200-35
PL28W-200-35
PL28X-200-50
PL28Y-200-50
PL28U-200-50
PL28V-200-50
PL28W-200-50

		Amphenol Technical Products International GZ				PART NAME:	
		第三角投影 THIRD ANGLE PROJECTION	页 面 SHEET	幅 面 SIZE	版 次 REV.	比 例 SCALE	PwrLok 8mm-90 1POS Plug Assy
签 名 SIGNATURE		日 期 DATE		UNLESS OTHERWISE SPECIFIED 1) All dimensions are in metric(mm). 2) Tolerances are as follows: 0 PL DEC ±1.00 1 PL DEC ±0.50 2 PL DEC ±0.20		DWG NO:	
制 图 DRAWN	Steven	03/07/19				PL28-200	
审 核 CHECKED		批 准 APPROVAL		Angles ±1°		N/A	
						CUST REV.	

THIS DRAWING IS SUPPLIED FOR INFORMATION ONLY. DESIGN FEATURES, SPECIFICATIONS AND PERFORMANCE DATA SHOWN HEREON ARE THE PROPERTY OF THE AMPHENOL CORPORATION. NO RIGHTS OF REPRODUCTION ARE IMPLIED. ALL DIMENSIONS ARE SUBJECT TO NORMAL MANUFACTURING VARIATIONS.

Customer Drawing

REV. ZONE			REVISIONS			
REV	ZONE	ECO	DESCRIPTION	DATE	BY	APPR
A	--	--	INITIAL RELEASE	07/14/15	RW	EC
B	--	--	Change back shell	11/17/16	SW	TS
C	--	--	Add rating current	03/07/19	Steven	JL

订购信息 Ordering Information

PL28 X - 20 1 - 50

键位及颜色 Key & Color	高压互锁 HVIL	线缆大小 Cable Size
"X", 橙色 Orange	0, 不带互锁 No HVIL	"50"=50mm ²
"Y", 黑色 Black	1, 带互锁 With HVIL	"35"=35mm ²
"U", 黄色 Yellow		"25"=25mm ²
"V", 绿色 Green		
"W", 红色 Red		

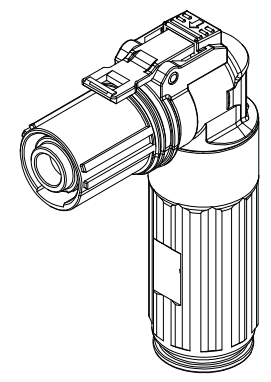
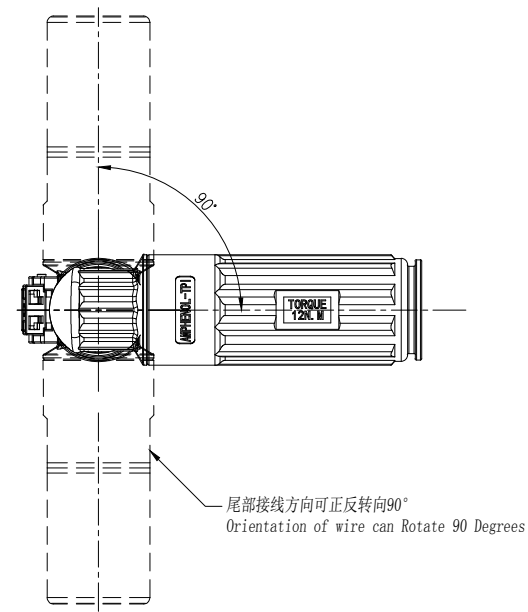

按键颜色见“订购信息”
The color of press key see “Ordering Information”

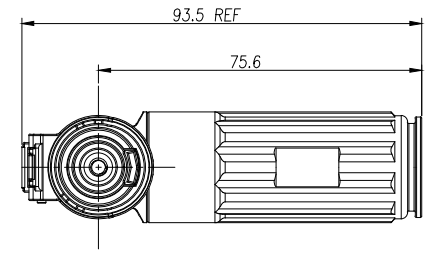
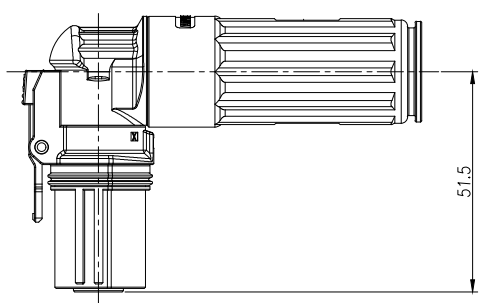
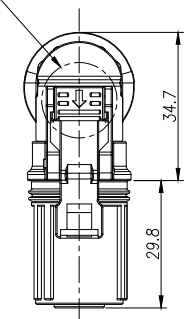

Standard Part List (With HVIL)

P/N
PL28X-201-25
PL28Y-201-25
PL28U-201-25
PL28V-201-25
PL28W-201-25
PL28X-201-35
PL28Y-201-35
PL28U-201-35
PL28V-201-35
PL28W-201-35
PL28X-201-50
PL28Y-201-50
PL28U-201-50
PL28V-201-50
PL28W-201-50

Standard Part List (Without HVIL)

P/N
PL28X-200-25
PL28Y-200-25
PL28U-200-25
PL28V-200-25
PL28W-200-25
PL28X-200-35
PL28Y-200-35
PL28U-200-35
PL28V-200-35
PL28W-200-35
PL28X-200-50
PL28Y-200-50
PL28U-200-50
PL28V-200-50
PL28W-200-50

规格参数 (Spec.):

- 工作温度 Operating temperature: -40° C~+125° C.
- 额定电流 Current rating(Connector Only): 50mm²-200 A 35mm²-150A 25mm²-120A.
- 额定电压 Operating voltage:1000 VDC.
- 耐电压 Dielectric withstanding voltage: 5000 VDC.
- 防护等级 Protection class:IP67 & IP2X.
- 电磁屏蔽 Shielding.
- 机械寿命 Mating cycle:100 Min.
- 带自动二次锁扣 Automatic secondary lock.
- 尾部接线方向可正反转向90° Rotate function of wire.
- 带高压互锁 Electrical interlock (HVIL).
- 配对插座 Mating receptacle : See drawing "PL00-200"

	Amphenol Technical Products International GZ					PART NAME: PwrLok 8mm-90 1POS Plug Assy	
	第三角投影 THIRD ANGLE PROJECTION	页面 SHEET	幅面 SIZE	版次 REV.	比例 SCALE	DWG NO: PL28-200	
签名 SIGNATURE 制图 DRAWN Steven		日期 DATE 03/07/19		1) All dimensions are in metric(mm). 2) Tolerances are as follows: 0 PL DEC ±1.00 1 PL DEC ±0.50 2 PL DEC ±0.20		CUST PART #: N/A	
审核 CHECKED YM Zeng		日期 DATE 12/02/19		UNLESS OTHERWISE SPECIFIED Angles ±1°		CUST REV. -	
批准 APPROVAL James Li		日期 DATE 12/02/19					